

## PRODUCT CONFIGURATION

### CHOOSE CONNECTIVITY OPTIONS

- 25A0013  
Staple Cartridges (3-pack)
- 27X0142  
MarkNet N8230 Fiber Ethernet Print
- 27X6410  
MarkNet N8372 Wireless Print Server
- 27X6510  
MarkNet N8370 Wireless Print Server
- 1021231  
Parallel Cable
- 1021294  
USB Cable
- 14F0000  
Parallel Interface Card
- 14F0100  
Serial Interface Card
- 57X9801  
256 MB Flash Memory
- 57X0204  
4 GB Memory
- 40C9200  
Forms and Barcode Card
- 40C9201  
IPDS Card
- 40C9202  
Prescribe Card
- 57X0185  
Secure Element Security Module
- 57X0300  
Contact Authentication Device
- 57X0300  
Contact Authentication Device
- 57X0301  
Contactless Authentication Device

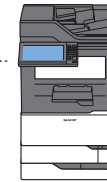
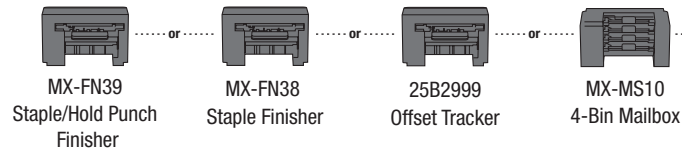

**MX-B557F**

Desktop Digital Multifunctional Document System  
Two Drawers (included)

### MX-B557F

Base model includes 10.1 inch color touch screen, wired connectivity, PCL 5e/6/XL, PostScript 3™ printing system, auto duplexing 2 x 550 sheet paper drawer, 100 sheet bypass tray. Includes toner (starter size 11K each) and drum included.

### CHOOSE PAPER FEED OPTIONS

#### Desktop Configuration

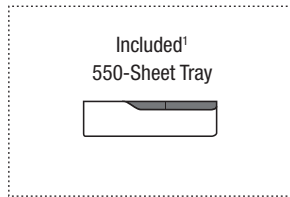

or

#### Floor Standing Console Configurations

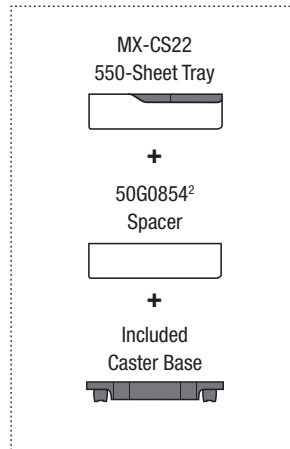

or

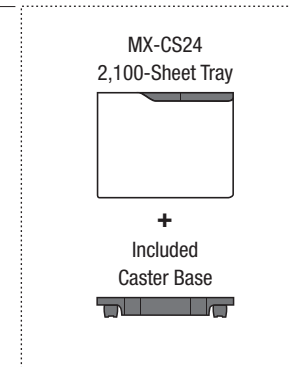

or

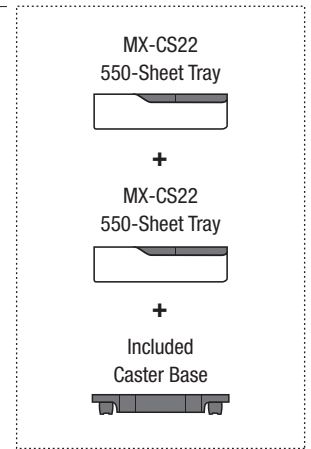

<sup>1</sup> Caster based must be removed for desktop use.

<sup>2</sup> Spacers must be configured under paper trays.

## SPACE REQUIREMENTS AND PLANNING

**MX-B557F**  
(standard drawers,  
table top)  
1,200-sheet maximum

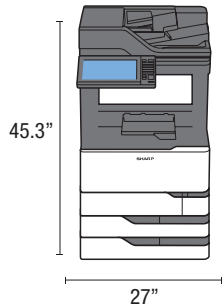

**MX-B557F + MX-CS22**  
(1 additional drawer,  
low floor standing)  
1,750-sheet maximum

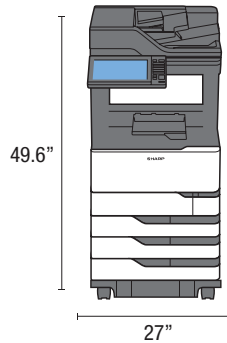

**MX-B557F + MX-CS22 + 50G0854**  
(1 additional paper drawer,  
spacer, floor standing)  
1,750-sheet maximum

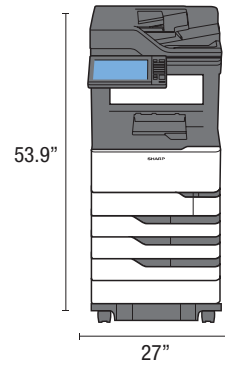

**MX-B557F + (2) MX-CS22**  
(2 additional paper drawers  
floor standing)  
2,300-sheet maximum

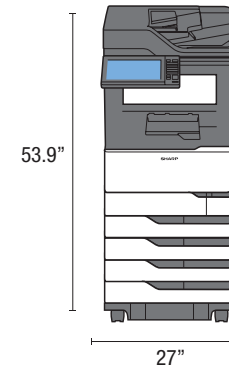

**MX-B557F + MX-CS24**  
1 additional paper drawer,  
floor standing)  
3,300-sheet maximum

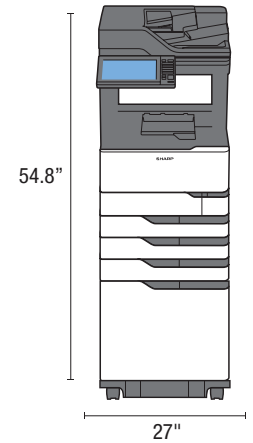

**Overhead View with Stand**

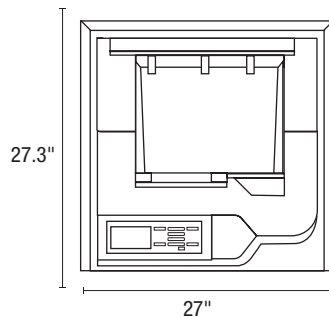

**Plan ahead to ensure your installation is a great success! Check the latest information on these products and have the following items available prior to installation.**

- **Firmware:** Check the Sharp-PC Service site to make sure the machine and accessories have the latest firmware prior to installation at the customer site.
- **Power Source:** Verify the power source at the customer site. Requires 110-127 V AC @ 60 HZ with a 15 A receptacle outlet and circuit breaker.
- **Product Keys:** Obtain application codes for any accessories that may require a product key prior to arrival at the customer site.
- **Supplies:** Verify that the customer has enough supplies on hand. Starter toner included.

MX-B70T Toner Cartridge  
MX-B70DU Drum

*Design and specifications are subject to change without notice. All product dimensions listed are approximate.*